

MOX-6 MediceL®

N.B. The specification is based on measurements made with cylinder gases using a flow rate of 100 mls min⁻¹. Conditions at 20°C, 50%RH, and 1013mBar unless otherwise noted.

Performance Characteristics

Output (see circuit)	11-15 mV with 300Ω external load resistance in 209mBar O ₂ @20°C
Range	0-1500mBar O ₂
Signal in 100% O₂	100±1%
Resolution	1mBar O ₂
Expected Operating Life	0,94 x 10 ⁶ % O ₂ hours @ 20°C 0.6 x 10 ⁶ % O ₂ hours @ 40°C
Operating Temp. Range	-20°C to +50°C
Pressure Range	0.5-2.0Bar
Zero signal in N₂ at 20°C	<200μV
Relative Humidity Range	0 to 99% non-condensing
N₂O Resistance	Resistant to 100% N ₂ O
Responce Time (air to 100% O₂)	T ₉₀ < 10s
Long Term Output Drift in (100% O₂)	<5% signal loss / year
Linearity	Linear 0-100% O ₂ (see note 1)
Housing Material	White ABS
Packaging	Sealed blister packaging
Cross-Sensitivity	Meets EN12598 requirements
Warranty Period	15 months from date of despatch (This amounts to a variation of condition 6 of our standard terms and conditions which otherwise apply)

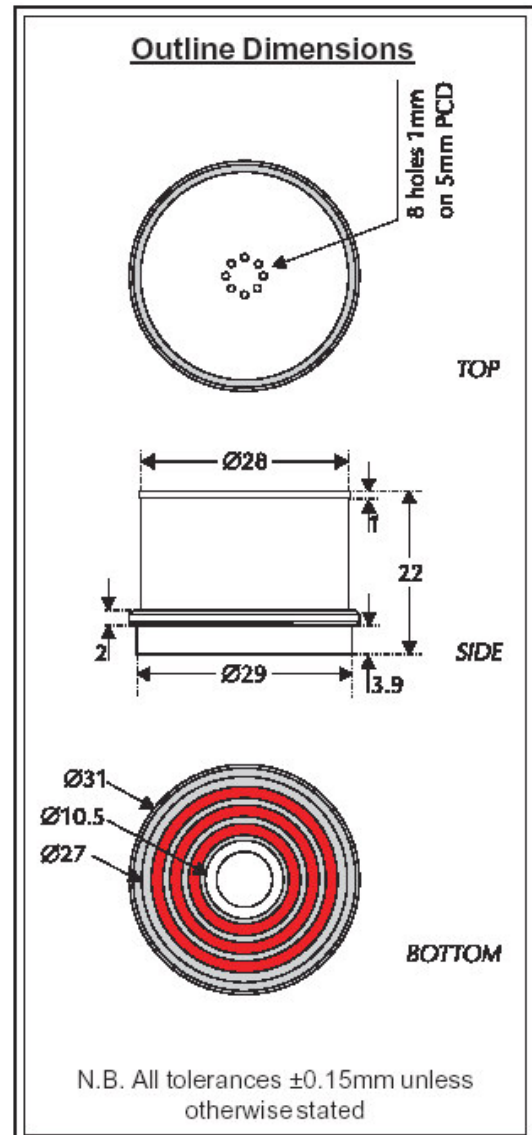

Note 1 : Use of aregression coefficient showsa best fit straight line better than 0,9995 when measured through the four data points N₂ ,21%O₂ and 100%O₂



Oxygen MediceL® Specification

Intended Use

These sensors are designed to be used to monitor the partial pressure of oxygen in anaesthesia, critical care, incubators and general Oxygen monitors.

Stabilisation time

Allow at least 15 minutes to stabilise in instrument before calibration.

Cleaning and Sterilisation

In case of contamination the sensor may be cleaned with distilled water and allowed to dry naturally. The sensor is not suitable for sterilisation by steam or exposure to chemicals such as ethylene oxide or hydrogen peroxide

Calibration Interval

These sensors are designed to have minimal drift over their useful lifetime however for maximum accuracy they should be calibrated in 100% Oxygen before use.

Cross-sensitivity

Test Gas	Error (%O ₂)
50% He / 50% O ₂	< 1%
80% N ₂ O / 20% C	+1 to +1,5%
4% Halotane / 28,8% O ₂ / 67,2% N ₂ O	+1,5 % to 2,0%
5% Sevoflurane / 28,5% O ₂ / 66,5% N ₂ O	+1 to +1,5%
5% Enflurane / 28,5% O ₂ / 66,5% N ₂ O	+1,2 to +1,8%
5% Isoflurane / 28,5% O ₂ / 66,5% N ₂ O	+1,2 to +1,8%
5% CO ₂ / 28,5% O ₂ / 66,5% N ₂ O	< 1%

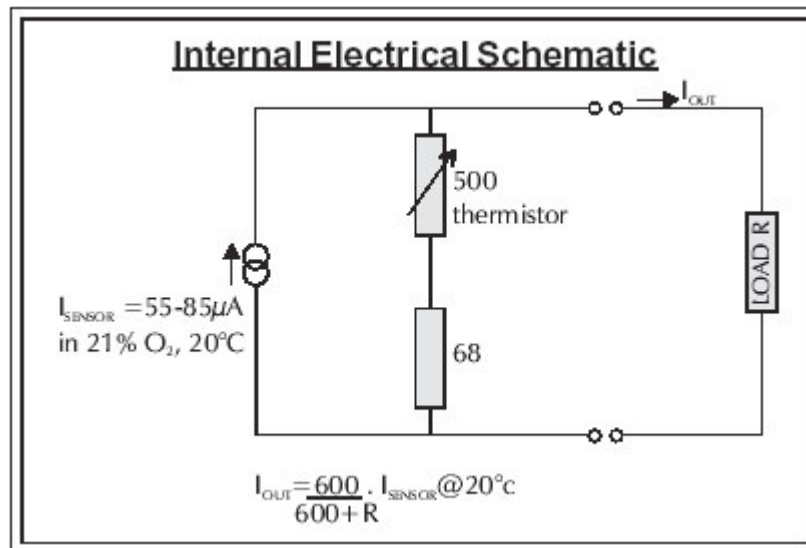

Every effort has been made to ensure the accuracy of this document at the time of printing. In accordance with the company's policy of continued product improvement City Technology Limited reserves the right to make product changes without notice. No liability is accepted for any consequential losses, injury or damage resulting from the use of this document or from any omissions or errors herein. The data is given for guidance only. It does not constitute a specification or an offer for sale. The products are always subject to a programme of improvement and testing which may result in some changes in the characteristics quoted. As the products may be used by the client in circumstances beyond the knowledge and control of City Technology Limited, we cannot give any warranty as to the relevance of these particulars to an application. It is the clients' responsibility to carry out the necessary tests to determine the usefulness of the products and to ensure their safety of operation in a particular application. Performance characteristics on this data sheet outline the performance of newly supplied sensors. Output signal can drift below the lower limit over time.